



**FOR IMMEDIATE RELEASE – 25 February 2009**

**Amarinth secures €2M order for 40 industrial process pumps  
from Aker Kvaerner for mega PTA Plant**

**Amarinth, a leading company specialising in the design, application and manufacture of pumps and associated equipment in the industrial, chemical & petrochemical industries, has secured an order in excess of €2M from Aker Kvaerner for 40 centrifugal industrial process pumps to be used in the new mega PTA plant in Portugal.**

The pumps will be installed at Artenius' new Purified Terephthalic Acid (PTA) plant which is being built in Sines, Portugal and will be used in the pumping of both clean fluids and slurry. Aker Kvaerner is providing the engineering, procurement services and construction management to the project.

This new plant, known as a mega PTA plant for its potential to produce one million tonnes of PTA per annum, will be one of the largest of its kind in Europe. It is due to be online in the first quarter of 2010. The PTA produced will be used for the production of polyester, PET resin for packaging, PET films, powder coating resins and synthetic fibres.

Amarinth are supplying a selection of A Series API 610 OH2 and C Series ISO 5199 pumps with installed powers ranging from 5.5KW to 315 KW that will meet the stringent hydraulic requirements for the project. Variable speed control will allow running speeds of between 1450 to 3850 rpm.

Manufactured from a mix of carbon steel and high-alloy duplex stainless steel, the pumps incorporate an innovative sliding baseplate to alleviate some of the piping loads. This baseplate enables the pumps to cope with rapidly changing volumes which would otherwise inject damaging jolts into the plant's pipework.

Oliver Brigginsshaw, Managing Director of Amarith, added: "Aker Kvaerner has worked on more than 21 PTA facilities spanning more than 20 years and is currently involved with a number of new PTA plants around the world. Based on our contract performance providing the pumps to meet this demanding application, we are looking forward to providing further pumps to Aker Kvaerner and other contractors of new mega plants around the world."

– END –

### OPTIONAL PANEL or BOX ITEMS

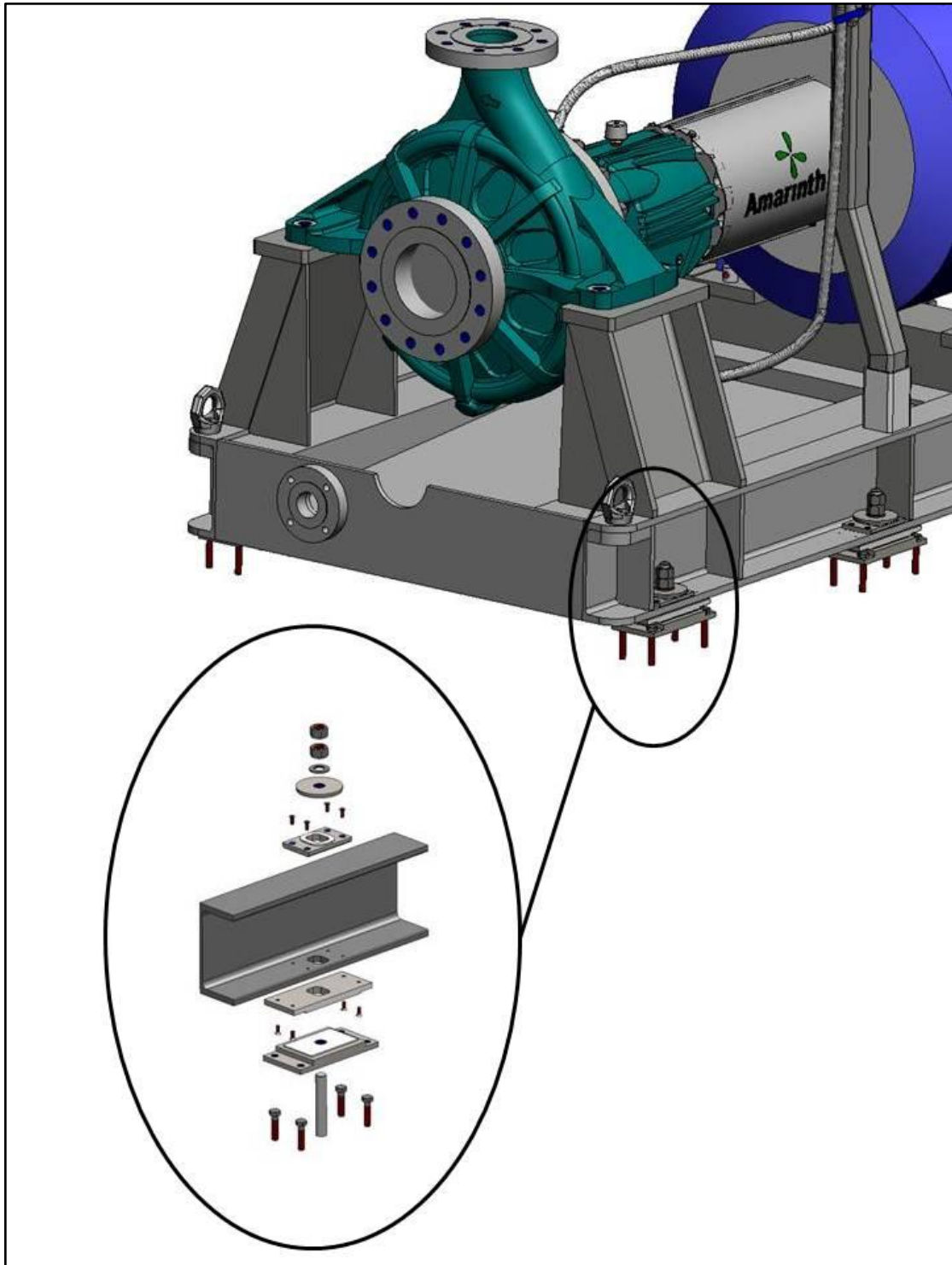

Sliding baseplate assembly

## NOTES TO EDITORS:

Founded in 2002, Amarith has harnessed the skills, creativity and passion of people who have worked in the pump industry for many years. Amarith delivers world-leading expertise in the design, application and manufacture of centrifugal pumps and associated equipment to ISO, ANSI & API standards, primarily for the industrial, chemical & petrochemical markets. Their portfolio includes:

- **Pumps:** Horizontal and vertical API 610 pumps, chemical and industrial pumps, many of which are interchangeable with the Girdlestone pump ranges, eliminating the need for expensive modifications when replacements are required.
- **Pressure Vessels:** Protect System Plan 52 and 53A and 53B sealant systems with inbuilt condition monitoring for pumps and mixers that are suitable for Safe area up to Zone I.
- **Spares & Service:** High quality, fast lead-time re-engineered spare parts to improve performance and extend pump life, including many which are directly interchangeable with the Girdlestone pump ranges.
- **Packages & Modules:** Condensate Recovery Units manufactured for Spirax Sarco incorporating the innovative Ci-Nergy intelligent variable speed control system, plus bespoke packages & skids built to order.
- **Business Systems:** state-of-the-art e-commerce technologies that deliver 24/7 support enabling customers to select pumps and place orders on-line and then track every stage of manufacture through to delivery, any time, anywhere in the world.

The company operates globally from its base in Rendlesham Suffolk, United Kingdom and has a customer base of world-leading companies, including BP, Shell, ExxonMobil, GlaxoSmithKline, Pfizer, Spirax Sarco, Diageo, AMEC, Fluor and Halliburton.

### For further information, electronic copy or photos contact:

#### Comment:

Steve Buckley  
Sales & Marketing Director  
Amarinth Limited  
Bentwaters Park  
Rendlesham  
Woodbridge IP12 2TW  
United Kingdom

Tel: +44 (0)1394 462122  
Mobile: +44 (0)7971 506 994  
Steve.Buckley@Amarinth.com

#### Media Relations:

Phil Harland  
B6 Solutions Limited  
29 Swan Drive  
The Wharf  
Aldermaston  
Reading RG7 4UZ  
United Kingdom

Tel: +44 (0)118 971 3790  
Mobile: +44 (0)7880 748380  
Phil.Harland@B6solutions.com

Amarinth can also be reached on its website: [www.amarith.com](http://www.amarith.com).

Go to our "Downloads" page at [www.amarith.com](http://www.amarith.com) to see all our press releases and find out more about us.