

## INDUSTRIAL PUMPS



Amarinth U Series pumps are designed for the General Industrial, Brewing, Distilling, Condensate and Effluent markets. A range of material options are available to match your application. The U Series pumps feature low NPSH designs and are fully interchangeable with the Girdlestone URF and USM ranges.

### General description

A range of single stage centrifugal end suction pumps with tangential discharge manufactured in a variety of alloys. All pumps and individual components are fully interchangeable with the equivalent Girdlestone URF / USM series units.

### Construction

Front pullout design with machined abutments

### Design methodology

Advanced computer techniques including 3D modelling & FEA

### Design standards

ATEX EC-Directive 94/9/EC

### Design pressure rating

10 bar g @ 20°C

### Suction pressure rating

6 bar g (long coupled)  
3.5 bar g (close coupled)

### Temperature rating

-10°C to 200°C (long coupled)  
-5°C to 120°C (close coupled)

### Performance envelope

#### Flowrate

Up to 500m<sup>3</sup>/h

#### Differential head

Up to 165m

#### Speed

Up to 3600 rpm

### Configurations

Long coupled pump  
Close coupled pump  
Bareshaft pump

### Frame sizes

050x040x159 to 150x125x274

### Design life

15 years (2 years uninterrupted operation)

# INDUSTRIAL PUMPS

## key features

- Cast iron, Stainless steel & Gunmetal material combinations
- All internal components interchange directly with Girdlestone URF & USM series pumps
- Long & close coupled models
- Major spare parts available off the shelf
- -10°C to 200°C temperature applications
- Single stage end suction centrifugal pumps with tangential discharge
- Robust design with machined abutments
- 2 years uninterrupted operation
- 6 bar pressure rating
- Semi open or shrouded impellers
- Tested to BSEN25199 / ISO 5199 – Head, Flow, NPSH, Noise & Vibration
- Standard and bespoke baseplate designs available
- ATEX compliance, on application

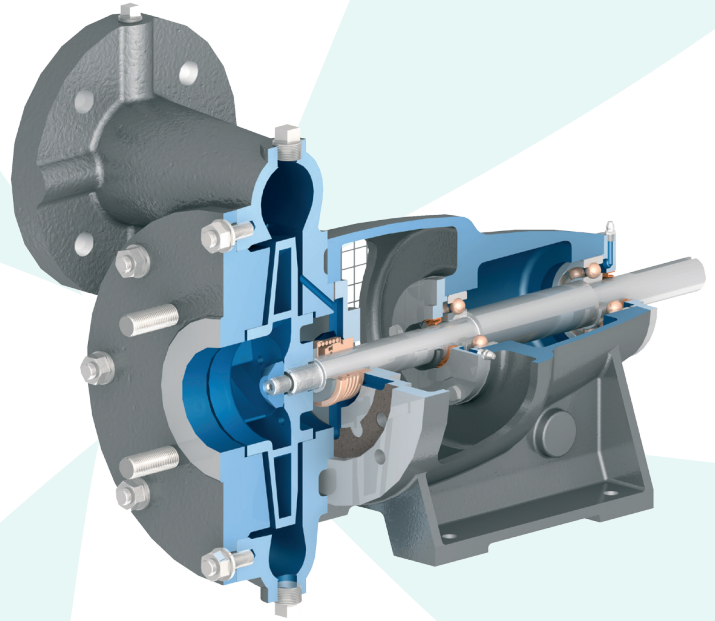

## materials

| Materials             | Casing                   | Impeller                 |
|-----------------------|--------------------------|--------------------------|
| Cast Iron / Cast Iron | BS EN 1561 Gr EN GJL 250 | BS EN 1561 Gr EN GJL 250 |
| Cast Iron / Gunmetal  | BS EN 1561 Gr EN GJL 250 | BS EN 1982 CC492K GS     |
| Cast Iron / SS 316    | BS EN 1561 Gr EN GJL 250 | ASTM A744 CF 8M          |
| SS 316 / SS 316       | BS 3100 316 C12          | ASTM A744 CF 8M          |
| Gunmetal / Gunmetal   | BS 1400 LG2              | BS EN 1982 CC492K GS     |
| Titanium / Titanium   | ASTM B367 Gr C2          | ASTM B367 Gr C2          |

## U Series hydraulic coverage

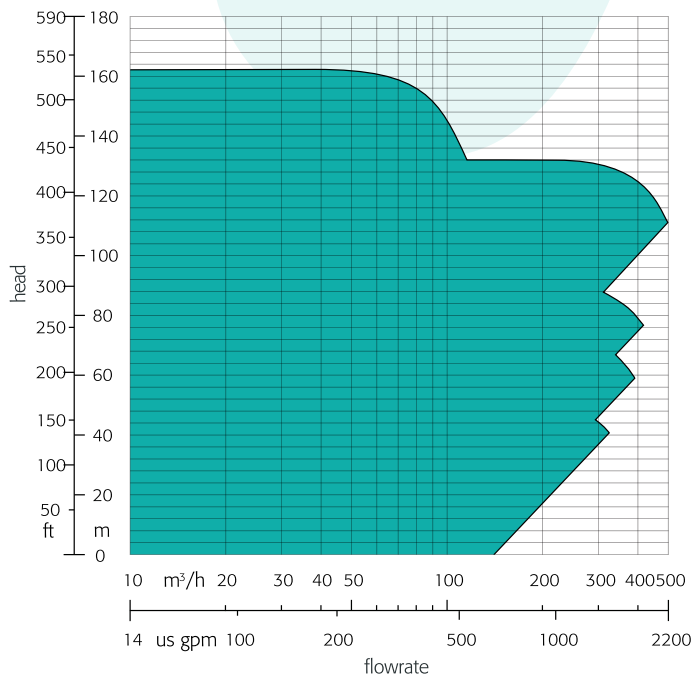

## typical applications

- Brewery processing
- Caustic transfer
- Condensate recovery
- Evaporator operation
- Low NPSH capabilities
- Seawater duties
- Water



**Amarinth**

Bentwaters Parks, Rendlesham, Woodbridge,  
Suffolk IP12 2TW. United Kingdom  
tel: +44 (0)1394 462 120  
fax: +44 (0)1394 462 130  
e-mail: [enquiries@amarinth.com](mailto:enquiries@amarinth.com)  
web: [www.amarinth.com](http://www.amarinth.com)



Certificate Number 3720  
ISO 9001, ISO 14001,  
OHSAS 18001